

# ROSS Inline High Shear Mixers with Solids/Liquid Injection Manifold 400 Series SLIM Specifications and Dimensions

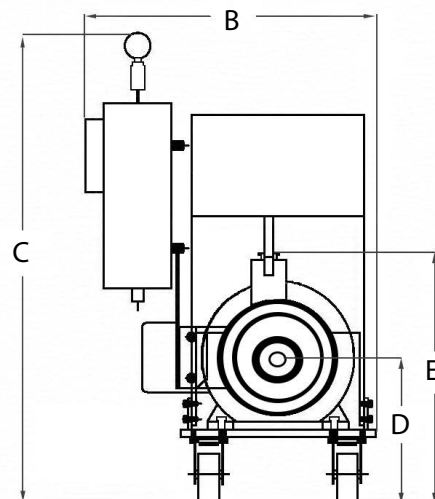
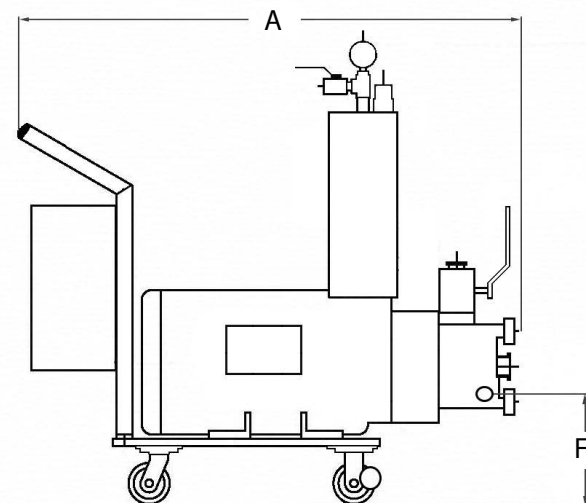

## STANDARD FEATURES:

- Driven by an explosion-proof motor designed for 230/460 volt, 3 phase, 50/60 Hz.
- Large square stator and special four-blade SLIM rotor.
- Double mechanical seal with Viton elastomers and barrier system.
- Stainless steel type 316 wetted parts polished to #4/32 Ra finish.
- Stainless steel type 304 cart with caster wheels for easy movement of mixer except for 450SC which is on leveling pads and forklift tubes for movement.
- All non-stainless steel external surfaces coated with a two-part acrylic urethane enamel paint.
- 2 ft<sup>3</sup> stainless steel 316 hopper for powder loading.

## AVAILABLE OPTIONS:

- Hose and wand attachment in addition to or in place of a hopper.
- Special elastomers including Kalrez.
- ANSI flange inlet and outlet connections, in lieu of tri-clamp.
- Hardened materials of construction such as a stainless steel type 440C stator, Stellite tipped rotor, or Kolsterised rotor and stator.
- Special motors including stainless steel, wash-down, and various voltages and frequencies.
- Controls include variable frequency drives, explosion-proof operator stations, and touch screen controls.

Model	HP	Rotor		Connection Size			Overall Dimensions			Distance From Ground			Weight	Maximum Flow Rate (Water)
		RPM	Diameter	Inlet	SLIM	Outlet	Length (A)	Width (B)	Height (C)	Inlet (D)	SLIM (E)	Outlet (F)		
401SC-15	15	3,600	2.5"	1.5"	1.5"	1.5"	44.2"	25.5"	36.9"	11.9"	22.1"	9.7"	750 lbs	90 gpm
			63.5 mm	38.1 mm	25.4 mm	38.1 mm	1,123 mm	648 mm	937 mm	302 mm	561 mm	246 mm	340 kg	340 lpm
405SC-25	25	3,600	3.5"	2"	1.5"	2"	50.2"	27"	45"	13.4"	23.5"	11.4"	900 lbs	330 gpm
			88.9 mm	50.8 mm	38.1 mm	50.8 mm	1,275 mm	686 mm	1,143 mm	340 mm	597 mm	290 mm	408 kg	1,250 lpm
430SC	30	1,800	7"	3"	2.5"	3"	53.5"	30.7"	45"	13.5"	29.3"	8.2"	1,200 lbs	800 gpm
			177.8 mm	76.2 mm	63.5 mm	76.2 mm	1,359 mm	780 mm	1,143 mm	343 mm	744 mm	208 mm	544 kg	3,028 lpm
450SC	50	1,200	10.5"	4"	3"	4"	58"	31"	35"	13.5"	34.1"	6"	2,100 lbs	1,600 gpm
			267 mm	101.6 mm	76.2 mm	101.6 mm	1,473 mm	787 mm	889 mm	343 mm	866 mm	155 mm	953 kg	6,057 lpm

\*Dimensions shown are approximate and subject to change without notice due to design improvements, selected options, or supplier component substitutions.